

# ARC Lamp Double Ended

Metal Halide lamps 70W, 150W and 250W

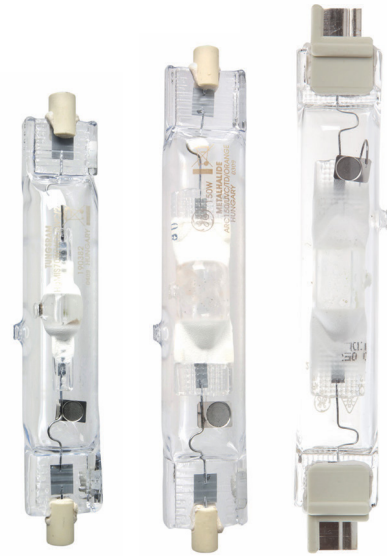

DATA SHEET

## Product Information

High brightness, high quality white and coloured light with good colour rendition, excellent colour consistency and energy efficiency make these lamps suitable for retail environments and commercial interiors. Lamps with UVC feature are optimal for museum and retail environments where UV control is important.

## Application Areas



Office



Commercial areas / city beautification / architectural



Retail



Industrial



Museum

## Basic data

Product Code	Product Description	Wattage [W]	Rated Wattage [W]	Weighted Energy Consumption [kWh/1000 hrs]	Volts [V]	Cap	Nominal Lumen [lm]	Rated Lumen [lm]	Rated Lamp Efficacy [lm/W]	Energy Efficiency Class (EEC)	CCT [K]	CRI [Ra]	Mercury Content [mg]	Average Life (horizontal) [h]	Pack Qty
<b>Arcstream™ Double Ended UVC</b>															
93102183	ARC70/TD/UVC/730/RX7s TU	70	75	82.50	95	RX7s	5,500	5,500	73	A	3,000	70	9.2	12,000	12
93102185	ARC70/TD/UVC/742/RX7s TU	70	75	82.50	95	RX7s	5,500	5,500	73	A	4,200	70	8.3	12,000	12
93102182	ARC150/TD/UVC/732/RX7s-24 TU	150	150	165.00	95	RX7s-24	12,000	12,000	80	A	3,200	70	14.5	12,000	12
93102184	ARC150/TD/UVC/742/RX7s-24 TU	150	150	165.00	95	RX7s-24	12,000	12,000	80	A	4,200	70	12.0	12,000	12
<b>Arcstream™ Double Ended RG-3</b>															
93102173	ARC250/TD/832/Fc2 TU	250	250	275.00	114	Fc2	20,000	20,000	80	A	3,200	75	15.5	12,000	12
93102174	ARC250/TD/842/Fc2 TU	250	250	275.00	115	Fc2	20,000	20,000	80	A	4,200	75	14.5	8,000	12
<b>Arcstream™ Double Ended Coloured UVC</b>															
93102163	ARC150/TD/UVC/GREEN/RX7s-24 TU	150	150	165.00	95	RX7s-24	9,000	9,000	-	B	Green	-	15.0	6,000	12

# Dimensions

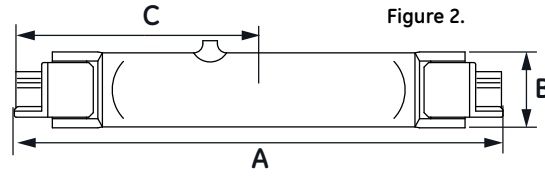
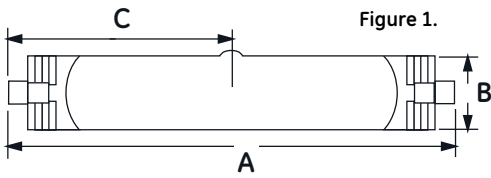

Wattage	A Length [mm]	B Diameter [mm]	C LCL [mm]	Cap	Operating Position	Bulb Glass	Mass [g]	Min. Start Temperature [°C]	Fig. No.
70	117.6	19	57±3	RX7s	HOR±45°	Quartz	21	-20	1
150	135.4	22	66±3	RX7s-24	HOR±45°	Quartz	30	-20	1
250	163.0	27.5	81.5±5	Fc2	HOR±45°	Quartz	53	-20	2

## Survival rate and lumen maintenance

The graph shows the survival of representative groups of lamps operated under control conditions at 10 hrs/start. Lamp life in service will be affected by a number of parameters, such as mains voltage deviations, switching cycle, luminaire design and control gear. The information given is intended to be a practical guide in determining lamp replacement schedules.

ARC LAMP UVC range & 250W/832 lamp survival and lumen maintenance

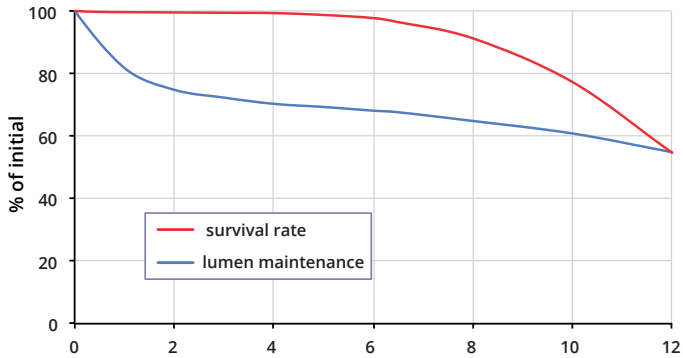

250W/842 lamp survival and lumen maintenance

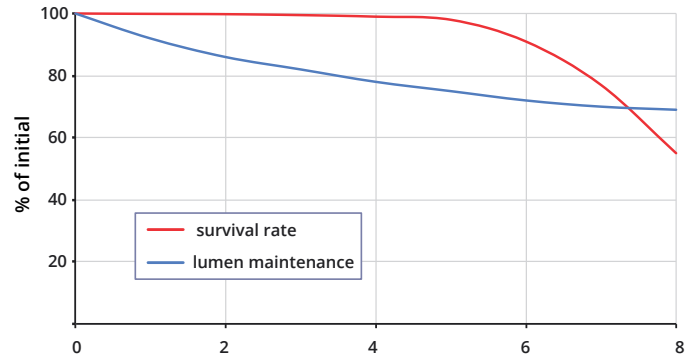

## UV Control lamps

Typical UV emission*	70W		150W	
	Warm white	Neutral white	Warm white	Neutral white
Watts	70	70	150	150
UV-C	0.0202	0.0082	0.0101	0.0547
UV-B	0.0113	0.0039	0.0052	0.0139
UV-A	9.5556	8.9326	7.7941	12.6254
E <sub>eff</sub>	0.0216	0.0085	0.0114	0.0453
PET	39.2	101.9	79.3	18.9

\*μW/(cm 2-nm) at 500lux

## RG-3 lamps

Typical UV emission*	250W	
	Warm white	Neutral white
Watts	250	250
UV-C	1.1033	3.5975
UV-B	1.1254	2.7137
UV-A	0.0041	0.0074
E <sub>eff</sub>	2.1014	5.9881
PET	0.40	0.14

\*μW/(cm 2-nm) at 500lux

## Coloured lamps

Typical UV emission	Green
UV-C	0.0049
UV-B	0.0098
UV-A	6.0934
E <sub>eff</sub>	0.0096
PET	87.3

\*μW/(cm 2-nm) at 500lux

# Spectral power distribution

3000K warm white spectral power distribution

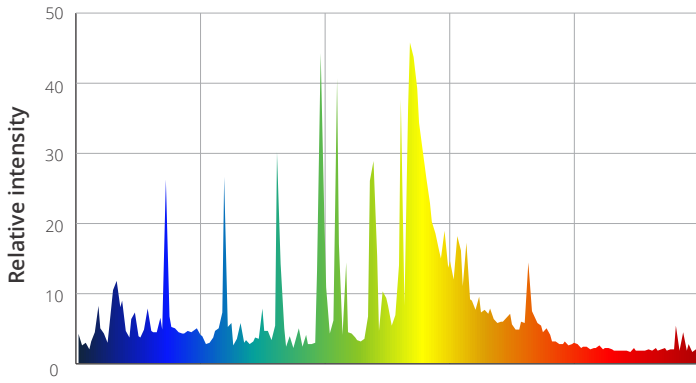

4200K daylight spectral power distribution

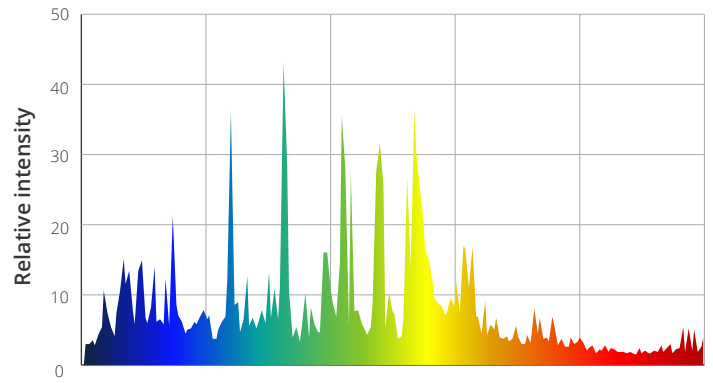

## Operating note

ARC LAMP Double Ended lamps have an outer bulb made of quartz which transmits UVA and UVB radiation. All metal halide lamps, including ARC LAMP Double Ended, operate with a high internal pressure and there is a slight risk that lamps may shatter, particularly if run beyond rated life. At end of life a switch off should be introduced every 24 hours to reduce the risk of shattering. The lamp must be fully enclosed by a luminaire to ensure the retention of any fragments in the event of such failure.

## Electrical data

Data is based on a nominal lamp operating from a nominal choke (reactor) ballast with power factor correction. Supply power will be based on the characteristics of the commercially available ballast.

## Lamp data

Wattage	Volts $\pm 10$ [V]	Current [A]	Power [W]	Maximum Current Crest Factor
70	95	0.98	75	1.8
150	95	1.8	150	1.8
250	100	3.0	250	1.8

## Run-up characteristics

Time for the light output to reach 90% of the final value is determined by supply voltage and ballast design. Typical value is three minutes.

## Hot re-strike time

All ratings re-strike within 10 minutes following a short interruption in the supply. Hot re-strike may be achieved using a suitable ignitor. Actual re-strike time is determined by ignitor type, pulse voltage and cooling rate of the lamp.

Typical run-up characteristics

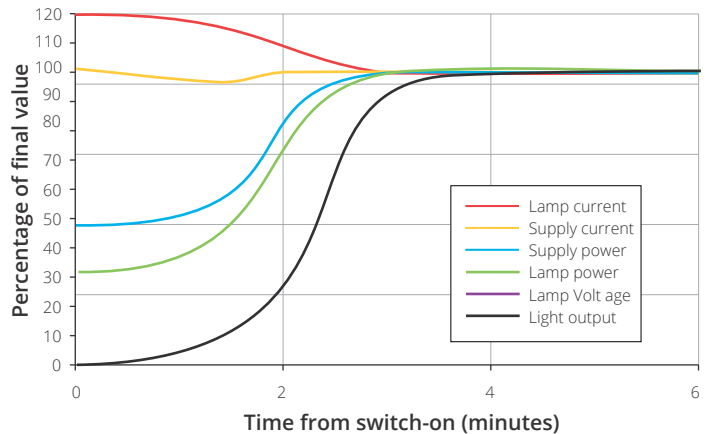

## Supply voltage

Lamps are suitable for supplies in the range 220V to 250V 50/60Hz for appropriately rated series choke (reactor) ballasts. Supplies outside this range require a transformer (conventional, high reactance or CWA) to ensure correct lamp operation. Lamps start and operate at 10% below the rated supply voltage when the correct control gear is used. However, in order to maximise lamp survival, lumen maintenance and colour uniformity the supply voltage and ballast design voltage should be within  $\pm 3\%$ . Supply variations of  $\pm 5\%$  are permissible for short periods only. This may be achieved by measuring mean supply voltage at the installation and selecting ballasts with appropriate settings.

## Effect of supply voltage variation

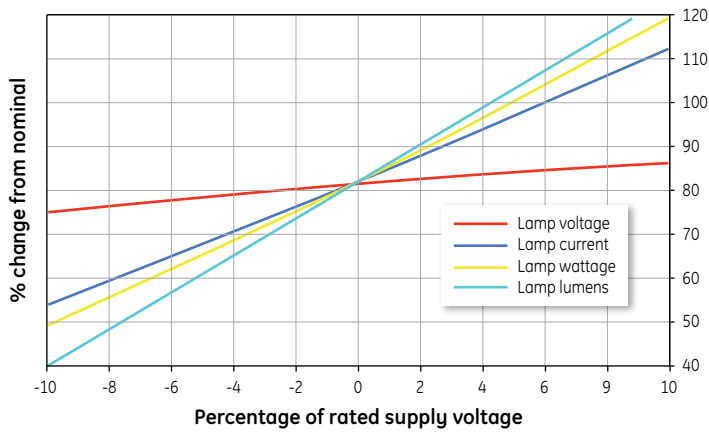

## Control gear

It is important to check the compatibility of lamp and control gear. Detailed information is given under "Guidance for luminaire manufacturers" section. It is essential to use a ballast appropriate to the supply voltage at the luminaire. Typical wiring diagrams for control circuits incorporating "Superimposed" or "Impulser" ignitor and choke (reactor) ballast are shown below. Refer to actual choke and ignitor manufacturers' data for terminal identification and wiring information.

### Typical superimposed ignitor circuit

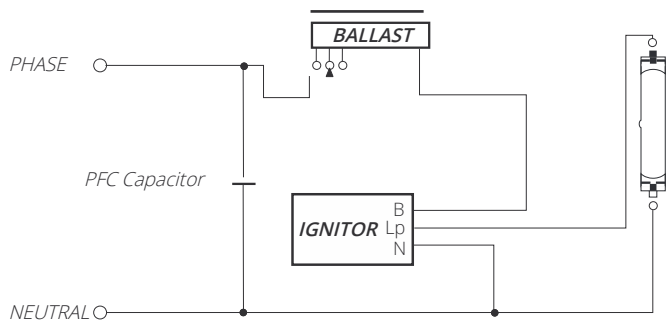

### Typical impulser ignitor circuit

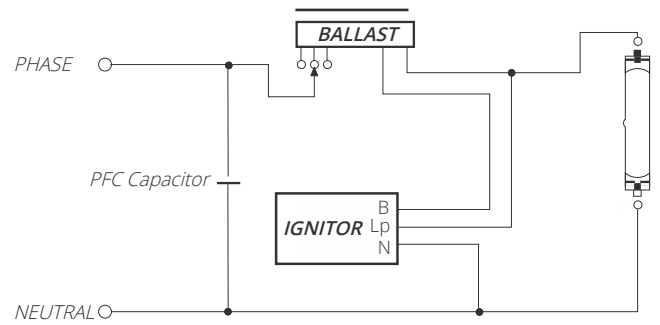

## Fusing of circuits

For a very short period after switch-on, all discharge lamps may act as a partial rectifier and as a result the ballast may allow several times the normal supply current to flow. To avoid nuisance fuse failure the ratings shown below should be used. Single fusing is recommended; MCB (type 3 or 4) or HBC fuse ratings:

Number of Lamps	1	2	3	4	5	6
70W Fuse Rating [A]	4	4	4	6	6	10
150W Fuse Rating [A]	4	6	10	10	16	16
250W Fuse Rating [A]	10	16	18	20	20	20

# Guidance for luminaire manufacturers

## Lamp operating temperature limits

Wattage	Maximum Cap Temperature [°C]	Maximum Bulb Temperature [°C]
70	250	500
150	250	650
250	250	650

## Control gear

To achieve correct lamp starting, performance and life it is important that lamp and control gear are compatible and suitable rated for the supply voltage at the luminaire.

## Ballasts

Lamps are fully compatible with ballasts manufactured for high pressure sodium lamps to IEC60662 and for metal halide lamps to IEC 61167. Ballasts should comply with specifications IEC61347-1 and IEC60923.

## Ballast thermal protection

Use of ballasts incorporating thermal cut-out is not a specific requirement but is a good optional safety measure for the installation.

## Ballast voltage adjustment

Series choke (reactor) ballasts incorporating additional tappings at  $\pm 10V$  of the rated supply voltage are recommended. Alternatively a single additional tapping 10V above the rated supply voltage will ensure lamps are not overloaded due to excessive supply voltage.

## Ignitors

Both Superimposed and Impulser type ignitors are suitable. It is recommended that only GE approved ignitors are used.

Ignitors should comply with specifications IEC61347-2 and IEC60927 and have starting pulse characteristics as follows:

Wattage	Min Pulse Voltage [kV]*	Min Pulse Width [ $\mu$ s]**	Min Pulse Repetition Rate***	Min HF Peak Current [A]
70	4.0	>1	2/cycle	>0.02
150	4.0	>1	2/cycle	>0.02
250	4.0	>1	6/cycle	>0.02

\* When loaded with 100 pF.

\*\* At 90% peak value.

\*\*\* From ignitor into lamp during starting. Pulse Phase Angle: 60-90° el. and/or 240-270° el.

## Timed ignitors

Use of a "timed" or "cut-out" ignitor is not a specific requirement, but it is a good optional safety feature for the installation.

The timed period must be adequate to allow lamps to cool and restart when the supply is interrupted briefly (see "Hot Re-strike Time"). A period of 5 minutes continuous or intermittent operation is recommended before the ignitor is automatically switched off. Commercially available 10/11 minute timed ignitors are suitable.

## Cable between ignitor and lamp

Cable connected between the lamp and a superimposed ignitor "Lp" terminal, or the ballast when using an impulser ignitor, must be rated at a minimum 50/60Hz voltage of 1000V. Mineral insulated cable is not suitable for connecting the lamp to the control gear. To achieve good starting superimposed ignitors must be adjacent to the luminaire. Cable capacitance of wiring between the ignitor "Lp" terminal and the lamp should not exceed 100pF (<1 metre length) when measured to adjacent earthed metal and/or other cables, unless otherwise stated by the ignitor manufacturer. When using impulser type ignitors longer cable lengths between ballast and lamp are normally permissible. Limits for particular ignitors are available on request from GE Lighting or directly from the ignitor manufacturer.

## PFC capacitors for simple choke circuits

Power Factor Correction is advisable in order to minimize supply current and electricity costs. For 220-250V supplies min. 250V rated capacitors are recommended as follows:

	70W	150W	250W
PFC Capacitor	10 $\mu$ F	20 $\mu$ F	30 $\mu$ F

